

# Rod Latch for Quarter-Turns L18 Pr20.1 RS/FS

1-350



## Advantages

- Applicable for quarter-turns with housing length 18mm.
- Rod latch applicable for round or flat rods.
- Dual rod holder.
- Quick assembly of the rods.
- Installation within the sealed area of enclosures.
- RH / LH application.
- At 90° operation - stroke 20mm.
- At 120° operation - stroke 27.5mm (for housings without 90° stop or cams without stop, the end stop is fixed by the rack).

## Material

- **Base plate:** PA, black
- **Driving rods, pinon:** zinc die, untreated
- **Washer:** steel, zinc plated

## Remarks

Mountable only with cam.

Use of negatively bended cams not possible.

Grounding of the quarter-turn with grounding nut possible.

1. stroke

2. round rod 201-9006.00-Lxxmm **not** usable.



## Rod latch for quarter-turns L18

	Product number	Rod fastening	Installation type	Delivery Unit
a)	200-9947.00-00000	quick-fit	snap-fit	1 pc.

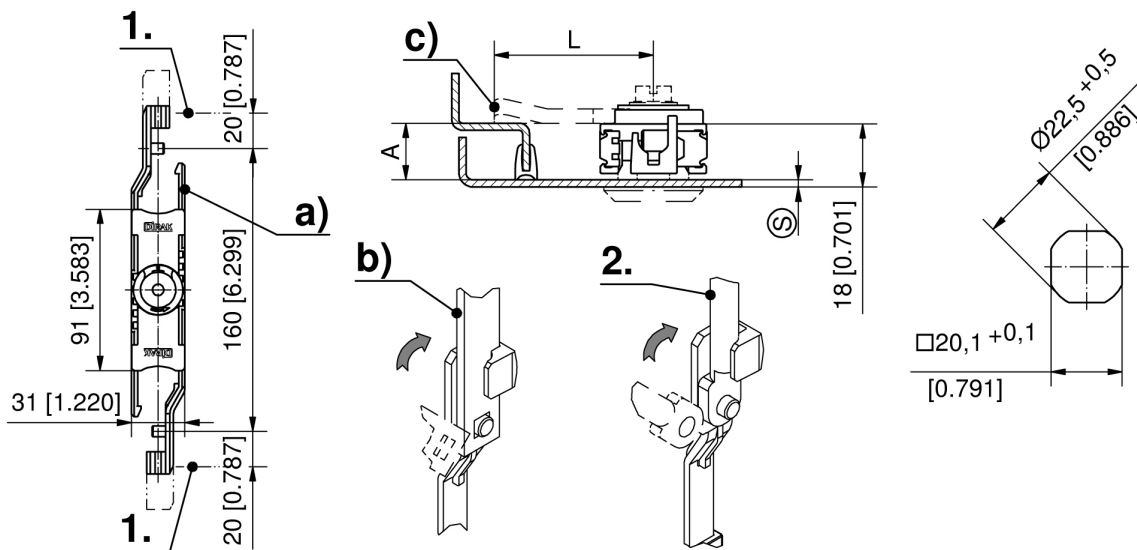

Formula for rods:  
cutout in the door center

$$L = \frac{\text{clearance} - 10\text{mm [0.394] (tolerance)} - \text{Rod Latch System in retracted condition}}{2}$$

