

# DST Swinghandle RS PrC

2-075DST



## Advantages

- Swinghandle with liftable operating lever with key cylinder and 2 keys.
- Tool-less installation.
- The swinghandle pre-assembled by DIRAK is hooked into the cutout provided and then clipped into place in the upper area.
- 90° Closing rotation.
- RH / LH application.
- Grounding by assembled grounding clip.
- On request available with pre-assembled cam / 3-point cam.
- A non-locked handle has a detent in the door-dish.



## Material

- **Handle and turning-disk:** zinc die, black
- **Dish:** PA, black
- **Stop:** zinc die, zinc plated
- **Grounding clip:** stainless steel
- **Locking cylinder and snap wedges:** PA

## Remarks

1. stroke 18mm
2. clearance

## Swinghandle

	Product number	Clamping range (S)	Latching type	Installation type	Delivery Unit
a)	407-9302.00-00015	1.2 mm - 1.7 mm	keyed alike DIRAK 1333	clip-in	1 pc.
a)	407-9302.00-00020	1.7 mm - 2.2 mm	keyed alike DIRAK 1333	clip-in	1 pc.
a)	407-9301.00-00015	1.2 mm - 1.7 mm	keyed different	clip-in	1 pc.
a)	407-9301.00-00020	1.7 mm - 2.2 mm	keyed different	clip-in	1 pc.
b)	407-9303.00-00015	1.2 mm - 1.7 mm	without lock, with plug	clip-in	1 pc.
b)	407-9303.00-00020	1.7 mm - 2.2 mm	without lock, with plug	clip-in	1 pc.

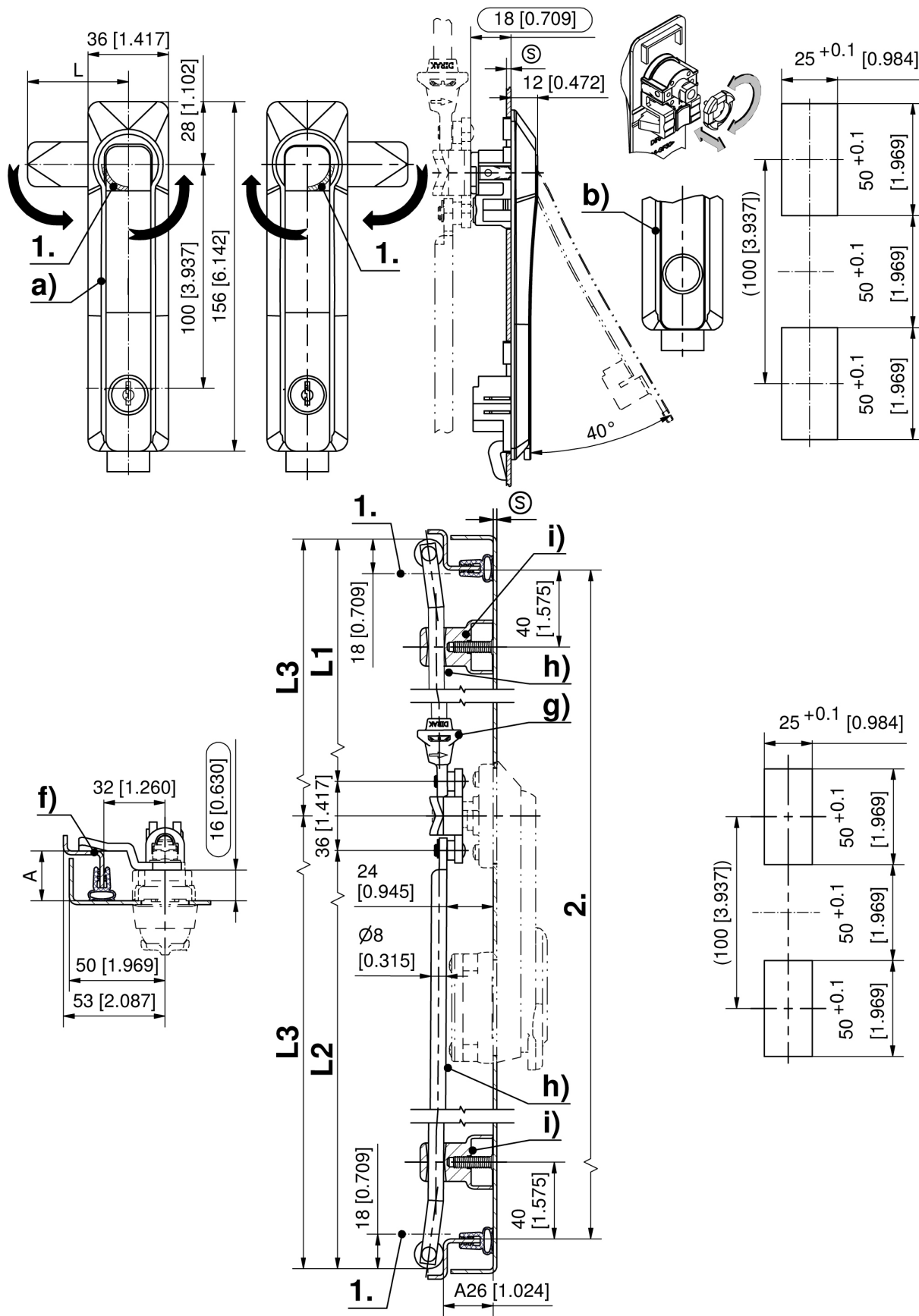

Formula for rods with eye and rollers:  
cutout in the door center (rod length varies)

$$L1 = \frac{\text{upper rod}}{2} = \frac{2 \cdot \text{clearance} - 12\text{mm}[0.472]}{2 [0.079]} - 50 \text{ mm} [1.969] \quad L2 = \frac{\text{lower rod}}{2} = \frac{2 \cdot \text{clearance} - 12\text{mm}[0.472]}{2 [0.079]} + 50 \text{ mm} [1.969]$$

cutout outside the door center (rod length equal)

$$L3 = \frac{2 \cdot \text{clearance} - 12\text{mm}[0.472]}{2[0.079]}$$