

DST Swinghandle RS PrC

2-085DST



Advantages

- Low profile design.
- 90° closing rotation. (1.)
- The pre-assembled swinghandle (single or 3-point cam) can simply be snapped into the cutout. (2./3.)
- RH / LH application is achieved by an adjustable cam stop. (4.)
- Key cylinder DIRAK 1333 with stainless steel dust cap and 2 keys.

Material

- **Swinghandle:** zinc die, black
- **Dish:** PA, black
- **Stop:** zinc die, zinc plated

Remarks

H-dimension of cam $\geq 16\text{mm}$

Drawings for rod calculation:

1. stroke 18mm
2. clearance



Swinghandle

Product number	Clamping range (S)	Latching type	Installation type	Delivery Unit
407-9606.00-00015	1.2 mm - 1.7 mm	keyed alike DIRAK 1333	clip-in	1 pc.
407-9606.00-00020	1.7 mm - 2.2 mm	keyed alike DIRAK 1333	clip-in	1 pc.

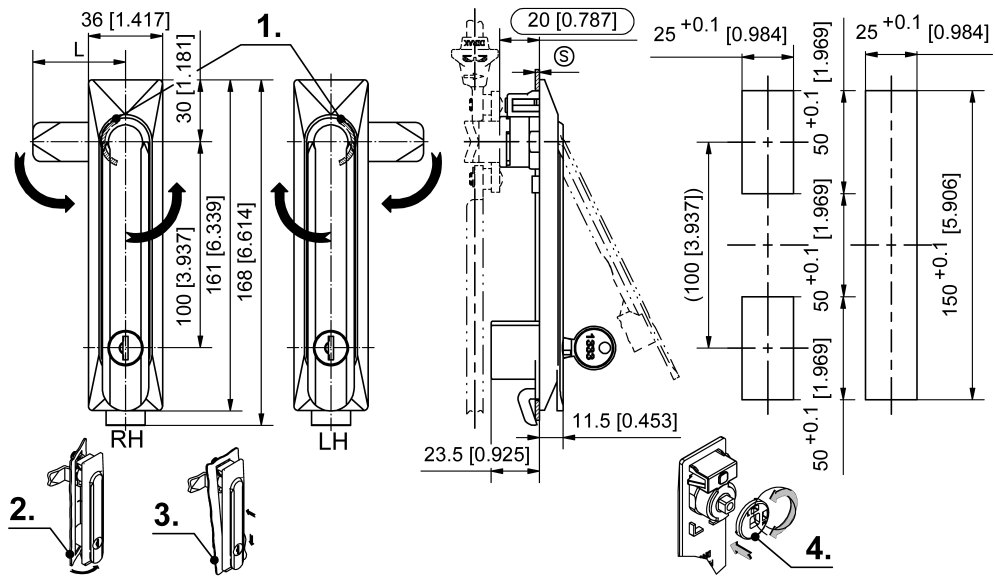

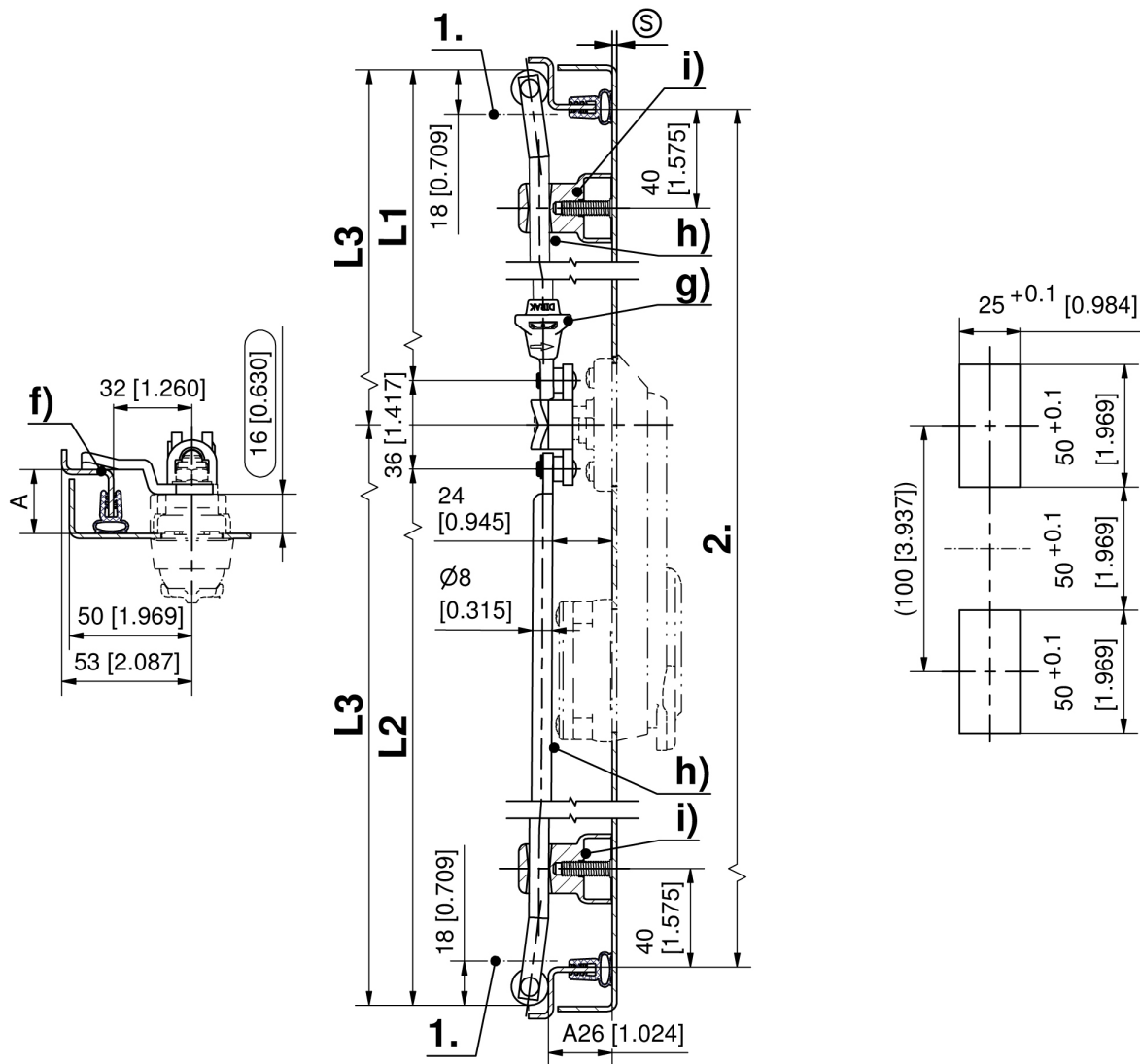

Formula for rods with eye and rollers:
 cutout in the door center (rod length varies)

upper rod

$$L1 = \frac{2 \cdot \text{clearance} - 12\text{mm}[0.472]}{2 [0.079]} - 50 \text{ mm} [1.969]$$

lower rod

$$L2 = \frac{2 \cdot \text{clearance} - 12\text{mm}[0.472]}{2 [0.079]} + 50 \text{ mm} [1.969]$$

cutout outside the door center (rod length equal)

$$L3 = \frac{2 \cdot \text{clearance} - 12\text{mm}[0.472]}{2 [0.079]}$$