

Wind Stop

6-200



Advantages

- Wind stop with automatic lock to keep the door open.
- RH / LH application.

Material

- **Wind stop:** steel, zinc plated

Remarks

Detailed dimensions see drawing.

Wind Stop

Product number	Version	Automatic lock	Delivery Unit
221-9001.00-00000	RH/LH	Yes	5 pcs.

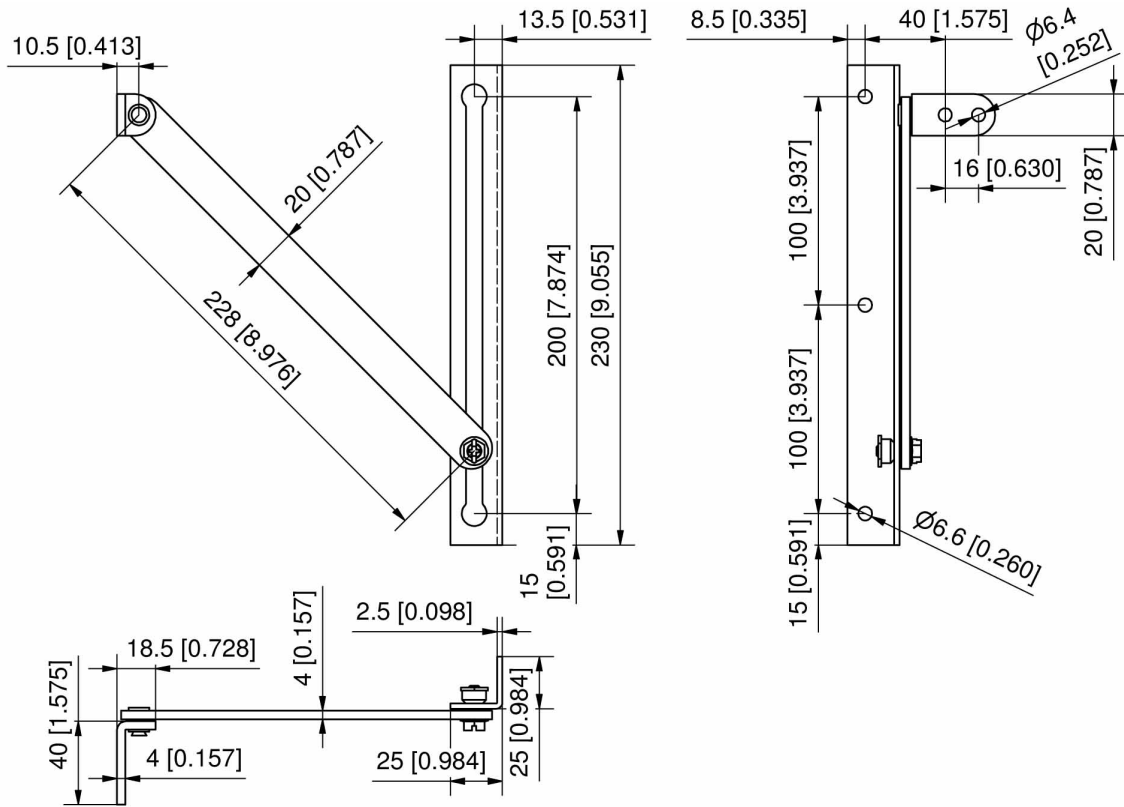

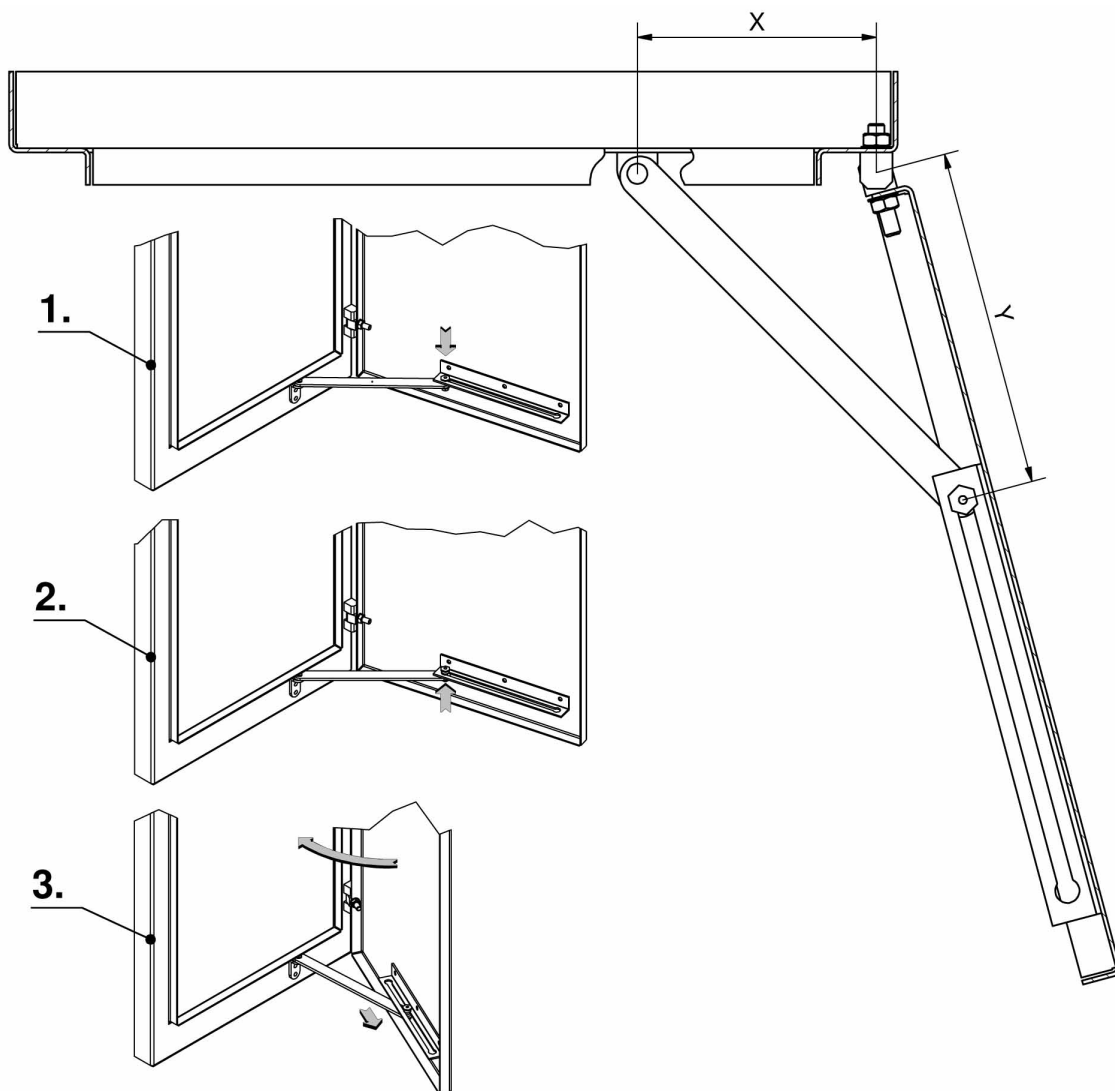

Wind Stop 221-9001.00-00000			
Opening Angle	minimal door width	approx. Dimension x	approx. Dimension y
90°	403 [15.866]	140 [5.512]	180 [7.087]
105°	389 [15.315]	120 [4.724]	166 [6.535]
120°	373 [14.685]	110 [4.331]	150 [5.906]
135°	369 [14.528]	100 [3.937]	146 [5.748]

•Opening angle can be varied by changing dimensions y and x.

1. engaged position, locking pin snaps into end position
2. push up the locking pin out of end position to unlock
3. lock, locking pin slides in the guide