

Pressure-Tight Fitting for 18mm Stroke RS

1-450

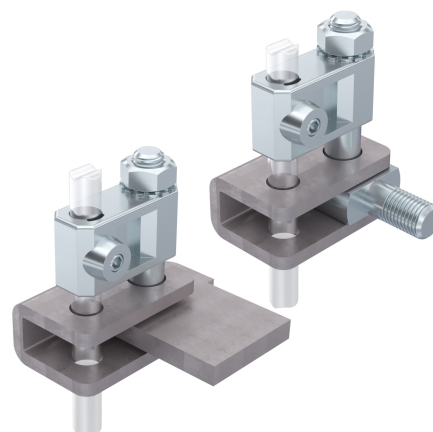

Advantages

- Fitting for pressure-tight doors.
- For high and medium voltage distribution boards.
- Controlled by rod latch, 18mm stroke.
- For insert, T- and L-handle and swinghandle.
- Suitable for round rod \varnothing 8mm.
- Redirect usable.

Material

- **Locking pin, fixing pieces, redirect, spacer, carrier, securing nut, c-clip, frame-part eye screw-on:** steel, zinc plated
- **Connector:** zinc die
- **Weld-on U-bracket, frame-part eye weld-on:** steel, untreated

Remarks

1. stroke

Pressure-tight fitting complete

	Product number	Installation type	Delivery Unit
a)	215-9001.00-00000	weld-on	1 pc.
b)	215-9002.00-00000	screw-on	1 pc.

Single parts

	Product number	Name	Material	Surface	Fastening type	Delivery Unit
d)	215-9005.00-00000	Redirect for pressure-tight door furniture	steel	zinc plated	screw-on	1 pc.
e)	215-0101.00-00000	U-bracket, series 235	steel	untreated	weld-on	1 pc.
f)	215-0501.00-00000	Locking bolt	steel	zinc plated	screw-on	1 pc.

	Product number	Name	Material	Surface	Fastening type	Delivery Unit
g)	215-9101.00-00000	Fastener	zinc die	untreated	screw-on	1 pc.
h)	215-0201.00-00000	Frame-part eye	steel	untreated	weld-on	1 pc.
i)	215-0401.00-00000	Frame-part eye	steel	zinc plated	screw-on	1 pc.

