

Rod Latch RS/FS PrA

3-100



Advantages

- For cutout A.
- The latch can be used with escutcheon, handles or swinghandle.
- Installation with or without cam.
- For application within the sealed area.
- Can also be used outside the seal in edge area.
- RH / LH application through double symmetry.
- Grounding by grounding clip (optional).

Material

- **Housing:** zinc die, untreated or PA, black
- **Pinion:** zinc die
- **Rods:** steel, zinc plated

Remarks

1. stroke 24mm
2. stroke 31.4mm



Rod latch, zinc die, untreated

	Product number	Pivoting range	Version	Stroke	Installation type	Delivery Unit
a)	208-9001.00-00000	135°	for inserts	24 mm	screw-on	1 pc.
b)	208-9008.00-00000	180°	for inserts	31,4 mm	screw-on	1 pc.
c)	208-9013.00-00000	135°	for inserts, without rod	-	screw-on	1 pc.
d)	208-9014.00-00000	135°	for inserts, with one rod	24 mm	screw-on	1 pc.

Rod latch, PA, black

	Product number	Pivoting range	Version	Stroke	Installation type	Delivery Unit
a)	208-9051.00-00000	135°	for inserts	24 mm	screw-on	1 pc.
b)	208-9058.00-00000	180°	for inserts	31,4 mm	screw-on	1 pc.

	Product number	Pivoting range	Version	Stroke	Installation type	Delivery Unit
c)	208-9063.00-00000	135°	for inserts, without rod	-	screw-on	1 pc.
d)	208-9064.00-00000	135°	for inserts, with one rod	24 mm	screw-on	1 pc.

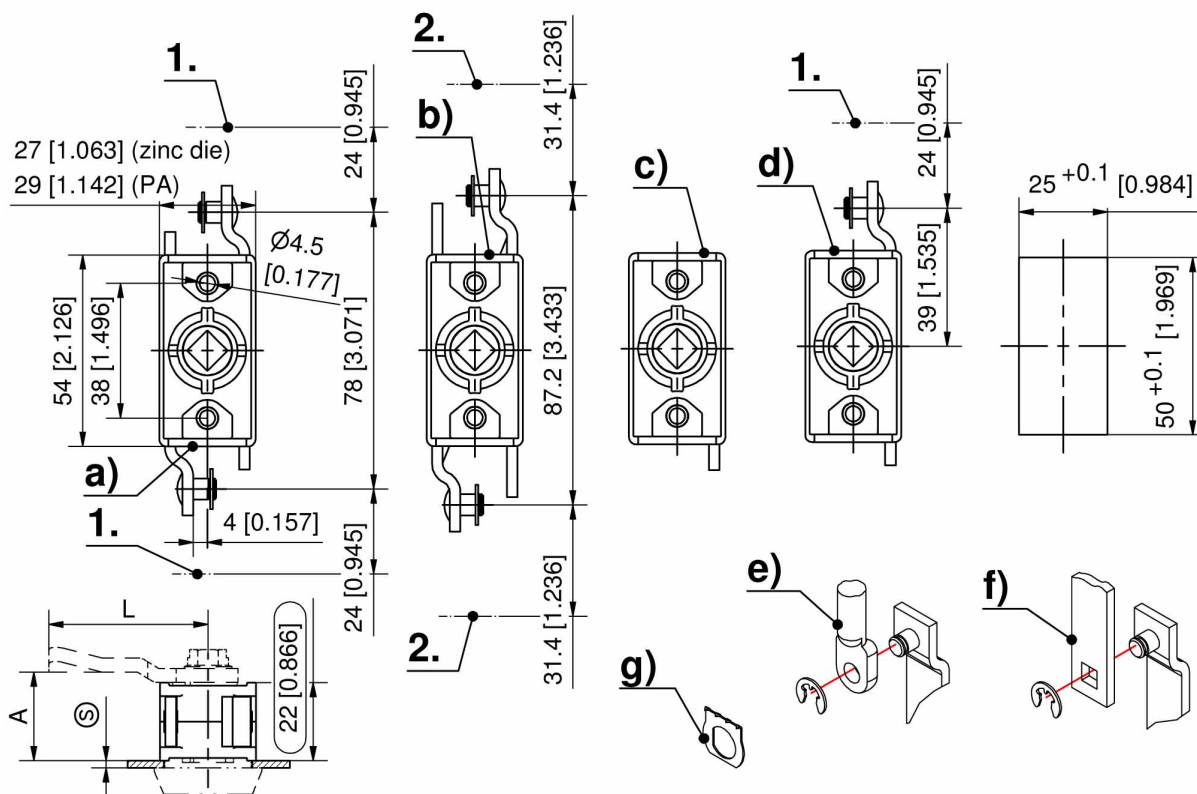

Formula for rods:
cutout in the door center

$$L = \frac{\text{clearance} - 10\text{mm [0.394] (tolerance)} - \text{Rod Latch System in retracted condition}}{2}$$
